

SMOOTH OPERATION EVEN IN CONFINED SPACES.

# PW23-PW30

4,500 – 6,000 LB CAPACITY ELECTRIC WALKIE



## 1. Efficient

### Enhanced System

Designed with an Alternating Current (AC) drive system, these walkies offer precise speed control, smooth directional changes and quiet operation with up to 23% improvement in energy efficiency than previous generation.

### Operator Control

Pallet positioning and pinwheeling in tight areas, like trailers, is easy with this walkie. The small footprint allows operators to easily maneuver in confined spaces, allowing for optimum productivity.

## 2. Comfortable

### Dual Controls

With controls mounted on both sides of the handle, operating the walkie is comfortable from either side of the truck and while working in confined areas.

### Smooth Operation

With up to 15% less effort required for steering than previous generation, and a long tiller arm, the handle assembly provides excellent comfort and exceptional maneuverability.

## 3. Smart

### Incline Performance

These walkies can achieve high levels of performance and control on grades – moving more pallets in less time. Even smarter, the optional 5-minute non-usage shut-off option provides energy conservation.

### Directional Reverse

The “smart” directional reverse switch is designed for activation only when traveling in a tractor-first direction, providing added protection for the operator and your application.

## 4. Durable

### Forks

Rolled steel forks provide excellent rigidity, strength and durability to the truck, allowing it to carry heavy-duty loads with ease. Diverse pallet entry guides also available for different applications.

### Short Battery Box

The short-battery box configuration of the PW23 features a 19.1” head length, making it easy to maneuver in congested areas and provides excellent visibility to the load.



CHARACTERISTICS				PW23		PW23		PW30	
1	Size			small		medium		medium	
2	Drive			electric		electric		electric	
3	Type of operation			walkie		walkie		walkie	
4	Load capacity / rated load	lbs	kg	4,500	2,041	4,500	2,041	6,000	2,721
5	Load center distance	in	mm	23.6	600	23.6	600	23.6	600
6	Load distance center (drive axle to fork)	in	mm	37.7 <sup>1)</sup>	958 <sup>1)</sup>	37.7 <sup>1)</sup>	958 <sup>1)</sup>	37.7 <sup>1)</sup>	958 <sup>1)</sup>
7	Wheelbase	in	mm	51.3 <sup>1)</sup>	1,302 <sup>1)</sup>	54.9 <sup>1)</sup>	1,394 <sup>1)</sup>	56.1 <sup>1)</sup>	1,423 <sup>1)</sup>
WEIGHTS									
8	Service weight including minimum battery (see line 6.5)	lbs	kg	926	420	941	427	1,193	541
9	Axle loading – loaded, drive / load	lbs	kg	1,776/3,650	806/1,655	1,782/3,659	808/1,660	2,694/4,497	1,222/2,040
10	Axle loading – unloaded, drive / load	lbs	kg	726/200	329/91	732/209	33/95	926/267	420/121
WHEELS, CHASSIS									
11	Tires			PU / PU		PU / PU		PU / PU	
12	Tire size, drive	in	mm	9.1x2.8	230x70	9.1x2.8	230x70	9.1x2.8	230x70
13	Tire size, load	in	mm	3.2x4.3	82x110	3.2x4.3	82x110	3.2x4.3	82x110
14	Additional wheels – dimensions <sup>3)</sup>	in	mm	3.9x1.6	100x40	3.9x1.6	100x40	3.9x1.6	100x40
15	Wheels – number, drive / load (x = driven wheels)			1x+2		1x+2		1x+2	
16	Tread, front	in	mm	20	510	20	510	20	510
17	Tread, rear	in	mm	14.3	363	14.3	363	14.3	363
DIMENSIONS									
18	Maximum fork height (MFH)	in	mm	4.8	122	4.8	122	4.8	122
19	Handle height in drive position, minimum / maximum	in	mm	29.5/48.7	750/1,237	29.5/48.7	750/1,237	29.5/48.7	750/1,237
20	Lowered fork height	in	mm	3.23	82	3.23	82	3.23	82
21	Overall length	in	mm	64.4	1,636	68.0	1,728	69.3	1,760
22	Length to fork face, headlength	in	mm	19.1	486	22.8	578	24.0	610
23	Overall width	in	mm	28.3	720	28.7	728	28.7	728
24	Fork dimensions, thick / width	in	mm	2.2/6.8/45.3	55/172/1,150	2.2/6.8/45.3	55/172/1,150	2.2/6.8/45.3	55/172/1,150
25	Overall width across forks	in	mm	21.1	535	21.1	535	21.1	535
26	Ground clearance, center of wheelbase	in	mm	1.1	30	1.1	30	1.1	30
27	Aisle width (for pallets 40" x 48" crossways) <sup>3)</sup>	in	mm	88 <sup>1)</sup>	2,238 <sup>1)</sup>	93.5 <sup>1)</sup>	2,376 <sup>1)</sup>	94.7 <sup>1)</sup>	2,405 <sup>1)</sup>
28	Aisle width (for pallets 40" x 48" lengthways) <sup>3)</sup>	in	mm	84.7 <sup>2)</sup>	2,151 <sup>2)</sup>	88.3 <sup>2)</sup>	2,243 <sup>2)</sup>	89.4 <sup>2)</sup>	2,272 <sup>2)</sup>
29	Turning radius	in	mm	58.4 <sup>1)</sup>	1,483 <sup>1)</sup>	62.0 <sup>1)</sup>	1,575 <sup>1)</sup>	63.1 <sup>1)</sup>	1,604 <sup>1)</sup>
PERFORMANCE									
30	Travel speed, loaded / unloaded	mph	kph	3.5/3.5	5.6/5.6	3.5/3.5	5.6/5.6	3.5/3.5	5.6/5.6
31	Lift speed, loaded / unloaded	ft / s	m / s	0.13/0.13	0.04/0.04	0.13/0.13	0.04/0.04	0.16/0.23	0.05/0.07
32	Lowering speed, loaded / unloaded	ft / s	m / s	0.16/0.13	0.05/0.04	0.16/0.13	0.04/0.05	0.16/0.13	0.05/0.04
33	Maximum gradeability, loaded / unloaded	%		8/20		8/20		8/20	
34	Service brake			electric		electric		electric	
MOTORS									
35	Drive motor (rating S <sub>2</sub> 60 minutes)	kW		1.1		1.1		1.7	
36	Lift motor rating at S <sub>2</sub> 10%	kW		1.2		1.2		2.2	
37	Battery according to DIN 43531/35/36 A, B, C, no			no. B		no. B		no. B	
38	Battery voltage	V/Ah		24,150		24,250		24,250	
39	Battery weight, minimum	lbs	kg	333	151	485	220	485	220
40	Energy consumption according to DIN EN 16796	kWh/h		0.34		0.34		0.37	
41	Turnover output according to VDI 2198	US t/h	t/h	128	117	128	117	163	163
42	Turnover efficiency according to VDI 2198	kWh/h		0.7		0.7		0.82	
OTHER									
43	Sound pressure level at the operator's seat	dB (A)		61		61		70	

1) Lowered load part: + 2.2 inches

2) Lowered load part: + 1.14 inches

3) Measurements include 7.9" safety clearance

## SAFETY STANDARDS

These trucks meet American National Standards Institute/Industrial Truck Standards Development Foundation, ANSI/ITSDF B56.1. UL-Classified by Underwriters Laboratories, Inc., as to fire and electric shock hazard only; Type E, Industrial Trucks. Users should be aware of, and adhere to, applicable codes and regulations regarding operator training, use, operation and maintenance of powered industrial trucks, including:

- ANSI/ITSDF B56.1.
- NFPA 505, fire safety standard for powered industrial trucks -type designations, areas of use, maintenance and operation.
- Occupational Safety and Health Administration (OSHA) regulations that may apply.

Specifications, equipment, technical data, photos and illustrations based on information at time of printing and subject to change without notice. Some products may be shown with optional equipment.

Call-out numbers shown in the diagram below correspond to the first column of the specifications chart.

# PW23

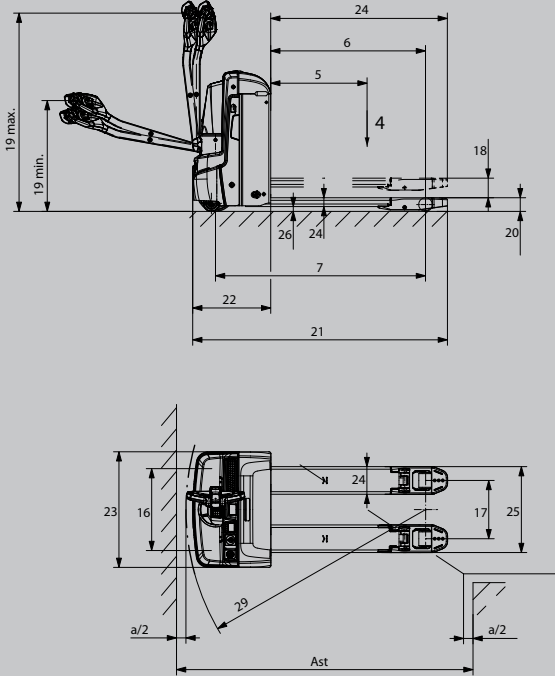

# PW30

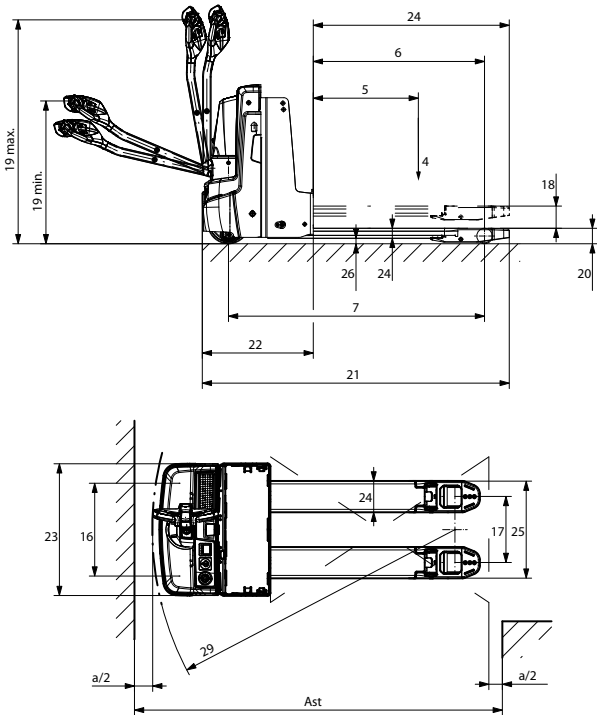

# PW23-PW30

4,500 – 6,000 LB CAPACITY ELECTRIC WALKIE

## Flexible Options

### 1. Reduced Wear And Tear

The optional ProTracLink stability caster wheel system helps stabilize the forklift when moving large or loose loads. The system evenly distributes forces during travel, helping to reduce the chance of damage when traveling over dock plates.

### 2. Easy Access

Optional 2-inch display keeps operator well informed at all times on battery discharge status, number of operating hours, event codes, and which program the truck is in, and truck can be accessed with key, Easy Access via soft-key, or PIN Code.

### 3. Enclosed Integrated Charger

The enclosed integrated charger option helps increase productivity by allowing convenient opportunity charging during breaks and lunches. The added benefit is increased uptime in extended shift operations.

### 4. Additional Improvements

Additional improvements include streamlined cables/wires for easier serviceability, speed control tiller for reduced speed in critical tiller angles, optimized load frame for increased productivity, unit reflectors, and many more.

### 5. Lithium-Ion Package

Lithium-ion batteries feature a lower cost of ownership than lead-acid batteries due to eliminating excessive maintenance costs. They can be charged to full capacity in a fraction of the time it takes to charge a lead-acid battery. Opportunity charging that can be interrupted at any time, prevents downtimes and ensures 24/7 truck usage. And this battery, vehicle, and charger are all synchronized with each other allowing for fast and efficient energy usage.



Manufactured with superior quality and exceptional value, Mitsubishi forklift trucks are supported by an extensive dealer and field support network located throughout North and South America. Don't forget to ask your local Mitsubishi forklift truck dealer about details on factory retail programs, financing plans and additional options and dealer services like planned maintenance and operator training.

© 2019 MCFA. All rights reserved. All registered trademarks are the property of their respective owners.

Some products may be shown with optional equipment.

MEHN0206-01

09/19

