

2100SJ

MEGA TELESCOPIC BOOM LIFT



- The world's largest self-propelled telescopic boom lift
- 5 steering modes, including lateral drive for exceptional maneuverability
- Industry-leading outreach
- Secondary platform controls for precise positioning
- Patent pending design

 **snorkel**™
www.snorkellifts.com

MEGA TELESCOPIC BOOM LIFT

2100SJ

DIMENSIONS	2100SJ*
Max. working height	216 ft
Max. platform height (A)	210 ft
Max. horizontal reach	100 ft
Platform size	8 ft x 3 ft
Overall width (B) (axles retracted)	8 ft 2 in
Operational width (axles extended)	18 ft
Stowed length (C)	49 ft
Stowed height (D)	10 ft
Ground clearance	9 in

PERFORMANCE	
Platform capacity (SWL) (unrestricted)	660 lbs
Platform capacity (SWL) (restricted)	1000 lbs
Max. drive height	210 ft
Max. wind speed	28 mph
Max. drive speed (stowed)	2.7 mph
Max. drive speed (elevated)	0.15 mph
Jib length	30 ft
Jib working arc	-55° to +73°
Platform rotation	150°
Superstructure rotation (continuous)	360°
Tailswing (axles retracted)	113 in
Tailswing (axles extended)	53 in
Raise/lower time	6.5/7 min
Gradeability	35%
Inside turning radius (axles retracted)	10 ft
Inside turning radius (axles extended)	8 ft 6 in
Outside turning radius (axles retracted)	16 ft 4 in
Outside turning radius (axles extended)	21 ft
Tires	445/50-710 foam filled 24 ply
Controls	proportional joystick
Drive system	4 wheel drive

POWER	
Power source	Deutz TCD 2.9L 74hp - Tier 4 Final

WEIGHT	
Weight	80,000 lbs

WORKING ENVELOPE

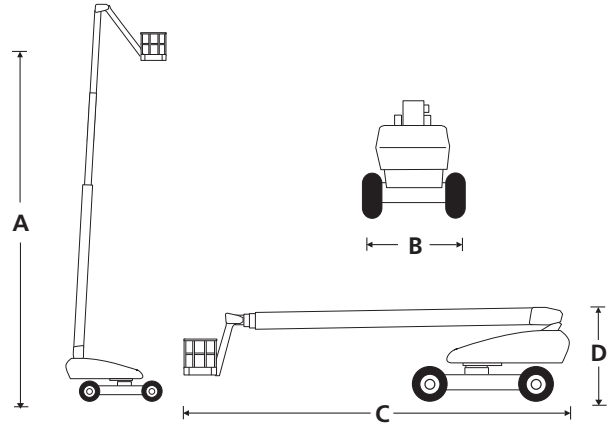
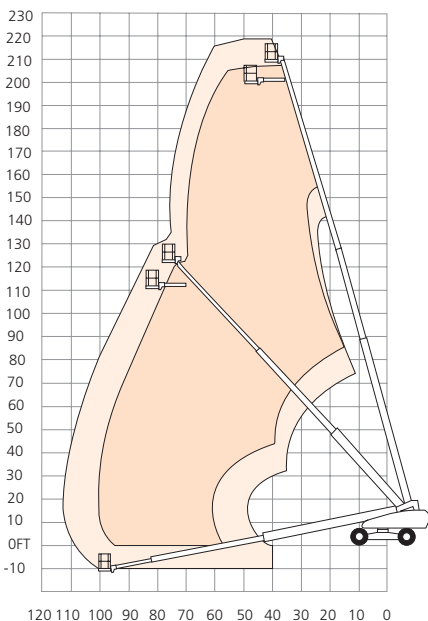

STANDARD FEATURES

- Snorkel Guard™ secondary guarding system
- Secondary platform controls
- Four wheel drive
- Hydraulic platform rotation
- 5 steering modes – front axle, rear axle, crab, complementary & lateral
- 360° continuous turntable rotation
- All proportional controls
- Tool tray
- Remote lower control panel
- Flashing amber light
- Dual lanyard attachment points
- Foam filled tires
- Power line to platform
- 2 year parts & labor, 5 year structural warranty
- ANSI compliant

OPTIONS

- Special paint colors
- Airline to platform
- Non-marking tires
- AC generator 110V/220V 2kW
- 100hp engine option
- Pressure washing package
- 10kW generator package
- 10kW generator/welder package
- Cold weather package
- Extreme cold weather package
- Extreme environment package
- Light package
- Glazier package
- Environmental hydraulic oil

snorkel www.snorkellifts.com

P.O. Box 1160
 St. Joseph, MO 64502-1160, USA
 Tel: 1 (785) 989-3000
 Toll-free: 1 (800) 255-0317
 Fax: 1 (785) 989-3070
 Email: sales.usa@snorkellifts.com