

ELECTRIC PALLET TRUCK

CAPACITY: 2,600 lbs.

MT12

SERIES 1131

Design

The MT12 features an effective parking brake to hold the truck on slopes or on truck tail lifts. A robust metal bumper protects the drive unit and components, while the low-profile chassis still allows dockboard use. A long, low-mounted tiller arm places the operator at a comfortable working distance from the truck.

Performance

The MT12 has been specially designed for low-hour applications in small retail stores, production lines, warehouses or goods transport sectors. Thanks to its powered traction and lift, the operator's physical input is minimized. Equipped with a 0.65 kW drive motor, the MT12 offers a highly cost-effective and productive solution for short distance transfer of loads up to 2,600 lbs. Its compactness guarantees maximum maneuverability when operating inside trucks or confined spaces.

Comfort

The compact and exchangeable Li-ION batteries allows opportunity charging via the external charger at any convenient power point for optimum uptime. All controls are located on the ergonomic tiller arm. The dual butterfly levers for traction and the lifting function can be easily operated by either hand to ensure precise operation.

Reliability

The durable drive unit of the MT12 delivers consistent high performance and reliability. The robust chassis has a reinforced fork structure for efficient handling of loads up to 2,600 lbs. The automatic lift stop at maximum lift height improved the quality and durability of components, protects the pump unit and reduces noise.

Service

The DC drive motor optimizes uptime between routine service periods and reduces service costs, while a reliable, energy-efficient controller delivers smooth handling performance. All truck data is immediately and easily accessible to the service engineer via the CAN-bus architecture.

TECHNICAL DATA

March 2018

| | | | | | |
|-----------------|---|---|---------------------------|------|--------------|
| Characteristics | 1.1 | Manufacturer | | | LINDE |
| | 1.2 | Model designation | | | MT12 |
| | 1.3 | Power unit | | | Battery |
| | 1.4 | Operation | | | Pedestrian |
| | 1.5 | Load capacity | Q | lbs | 2600 |
| | 1.7 | Load center | c | in | 24 |
| | 1.8 | Axle center to fork face | | in | 34.6 |
| | 1.9 | Wheelbase | y | in | 44.1 |
| | Weights | 2.1 | Service weight (+/- 5.0%) | | lbs |
| 2.2 | | Axle load with load, front/rear | | lbs | 933/2006 |
| 2.3 | | Axle load without load, front/rear | | lbs | 251/48.4 |
| Wheels | 3.1 | Tires Cushion, SE, pneumatic, polyurethane | | | PU |
| | 3.2 | Tire size, front | | in | 8.3 x 2.8 |
| | 3.3 | Tire size, rear | | in | 3.1 x 2.4 |
| | 3.5 | Wheels, number front / rear (X=driven) | | | 1x/2 |
| Dimensions | 4.4 | Lift | h_3 | in | 4.5 |
| | 4.9 | Height of tiller arm in operating position, min/max | h_{14} | in | 31.5/46.0 |
| | 4.15 | Height, lowered | h_{13} | in | 3.12 |
| | 4.19 | Overall length | l_1 | in | 60.5 |
| | 4.20 | Length to fork face | l_2 | in | 15.4 |
| | 4.21 | Overall width | h_0/b_1 | in | 27.0 |
| | 4.22 | Fork dimensions | s/e/l | in | 2 x 5.9 x 45 |
| | 4.25 | Fork spread | b_5 | in | 27.0 |
| | 4.32 | Ground clearance, center of wheelbase | m_2 | in | 1.1 |
| 4.34 | Aisle width with pallet 31x40 along forks | A_{st} | in | 81.2 | |
| Perf. | 5.1 | Travel speed, with/without load | | mph | 2.5/2.8 |
| | 5.8 | Maximum gradeability with load | | % | 4.0/10.0 |
| | 5.10 | Service brake | | | Electric |
| Drive | 6.1 | Drive motor rating S2 60 min | | kW | 0.65 |
| | 6.2 | Lift motor rating at S3 10% | | kW | 0.50 |
| | 6.3 | Battery according to DIN 43531/35/36 A,B,C, no | | | Li-ION |
| | 6.4 | Battery voltage/rated capacity (5h) | | V/Ah | 24/20 |
| | 6.5 | Battery weight (\pm 5%) | | lbs | 8.1 |
| 8.1 | Type of drive unit | | | | DC |

STANDARD / OPTIONAL EQUIPMENT

Standard Equipment

- > Drive wheels: polyurethane
- > Single polyurethane load wheels
- > 2.8 mph travel speed
- > Li-ION battery 24V/20Ah
- > Switch - USB type
- > Electromagnetic brake
- > Automatic parking brake
- > Forks 45.25 in. long by 27 in. wide
- > Belly switch on tiller head
- > CAN-bus technology
- > Horn

Optional Equipment

- > Fork length / width
- > Extra battery Li-ION 24V/26Ah

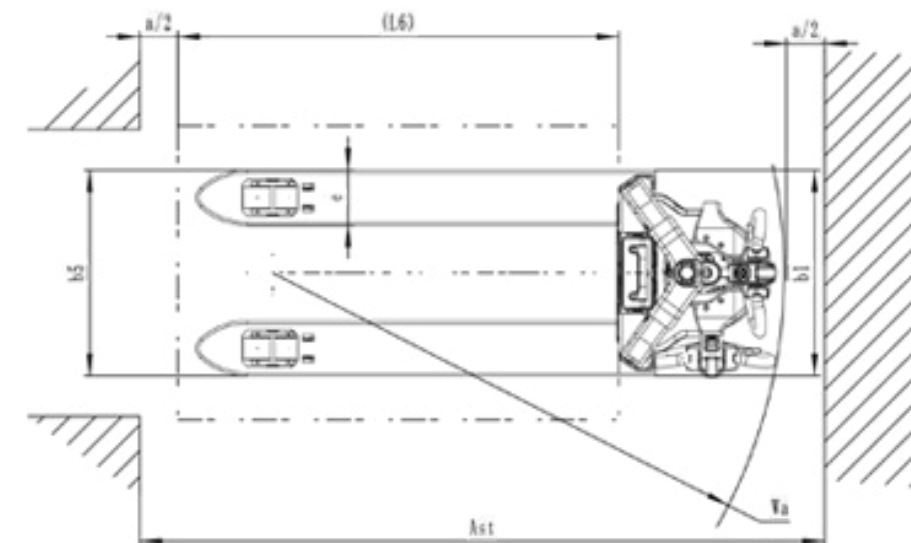
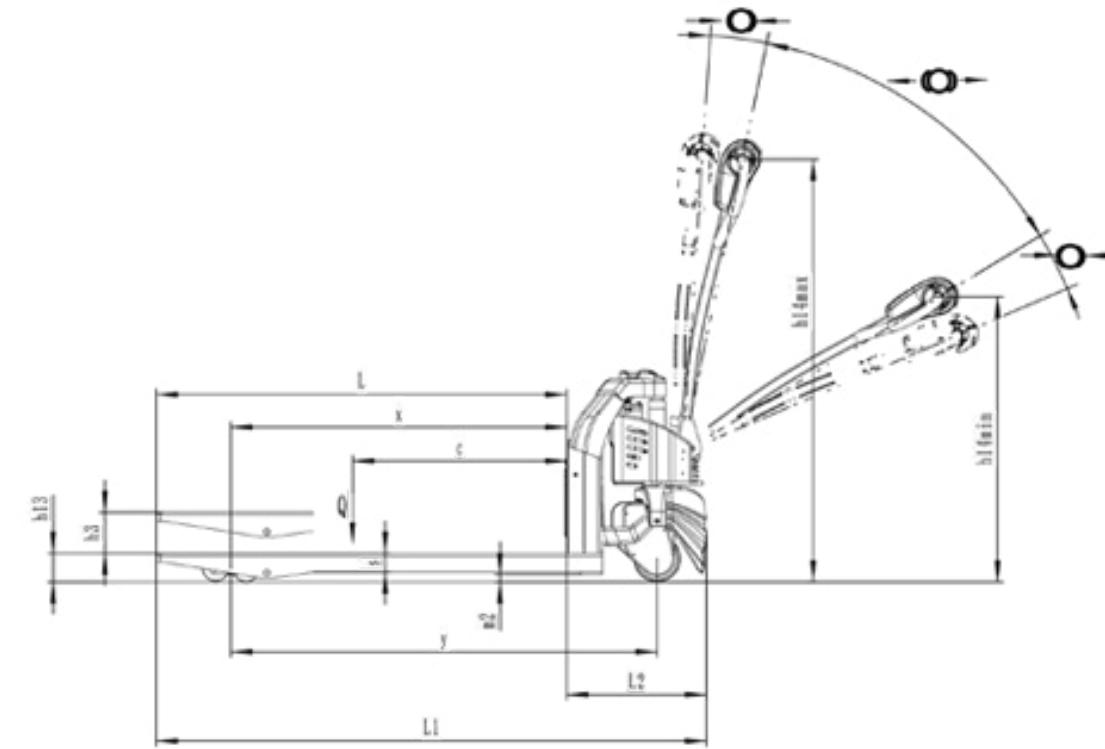

FEATURES

Traction and Lift System

- > 0.65 kW DC drive motor
- > Adjustable parameters: travel speed (up to 2.8 mph) and acceleration
- > Electrical lifting
- > Manual lowering



Chassis

- > Robust metal bumper protects drive system and components
- > Features a low chassis skirt but still allows dockboard use
- > Long, low-mounted tiller ensures operator is comfortable distance from the truck
- > Rugged, reinforced fork structure provides safe handling of loads up to 2,600 lbs.

Braking System

- > Highly-efficient electromagnetic brake applied by moving the tiller to fully up or down position
- > Automatic braking on releasing traction butterfly or reversing direction
- > Truck slows before coming to a stop, remaining under total control at all times
- > Quick-disconnect power cutoff

Display

- > Reliable and precise battery discharge indicator
- > Operating hour meter
- > Faults code indication
- > Battery management system



Battery

- > Plug and play system
- > Li-ION technology
- > 20Ah (standard) and 26Ah (optional)
- > Up to 3 hours of use
- > 2.5-hour charging time

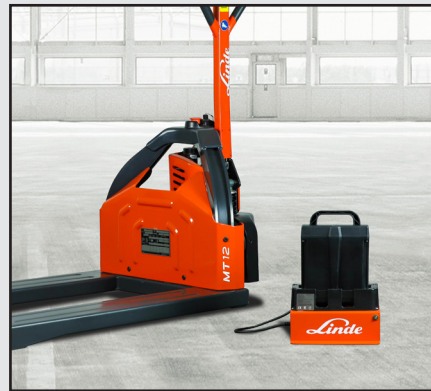

External Charger

- > Enables opportunity charging at any convenient power point
- > Easy plug and fast charging
- > Wall-mounted



Controls

- > Traction and lift controls grouped on ergonomic tiller head
- > Dual butterfly control levers for use with either hand
- > Control lever for manual lowering
- > Belly switch on tiller head stops truck when actuated
- > Key switch - USB type

For more information on Linde material handling equipment, please contact:

KION North America Corporation
2450 West 5th North Street, Summerville, SC 29483
Phone: (843) 875.8000 Truck Sales Fax: (843) 875.8471
Email: trucksales.na@kiongroup.com
www.kion-na.com