



# **ELECTRIC PNEUMATIC TIRE FORKLIFT**

9,000-12,000 LB CAPACITY

THE HEAVY-DUTY ELECTRIC TRUCK



# HAVE BIGGER EXPECTATIONS

AND EXPERIENCE REAL PRODUCTIVITY



Experience levels of performance able to compete with IC engine forklifts while taking full advantages of the benefits electric forklifts bring to the table: quiet operation, intelligent performance systems, zero emissions and lower total cost of ownership.

These trucks are designed to operate in the toughest applications. Common industries include:

- Transportation equipment
- Wholesale trade - durable goods
- Paper and allied products
- Textile mill products
- Fabricated metal products
- Stone, clay and glass
- Food and kindred products

## **An Investment To Count On**

Designed for durability and reliability, the robust construction of these units can help to reduce repair and replacement needs and can increase the residual market value of the truck. Simple plug-in diagnostics, easy access to major components and the easy-to-use multifunction display help to reduce downtime and maintain efficient performance.

## **Performance On Demand**

The powerful and responsive AC drive system provides performance levels offering a zero emissions alternative to traditional IC customers that have high expectations when it comes to productivity. Various integrated systems allow for intelligent control and adjustment in a wide array of operating environments.

## **Comfort And Safety**

The comfortable, quiet and heavily-equipped operator compartment allows for precise (and low effort) control to provide confident, stress-free and enjoyable operation.

## **Comfort**

This truck has been created with features and benefits in mind to help keep the operator refreshed and revitalized during a long shift.



<b>Standard Features</b>	<b>Standard</b>	<b>Optional</b>
80V AC Drive System	●	
Preset ECO and PRO performance modes	●	
Side battery extraction	●	
Multifunction, interactive, full-color display	●	
Cornering speed control	●	
Standard wet disc brakes	●	
TruckTool diagnostics	●	
Integrated Presence System (IPS)	●	
Full-suspension vinyl Grammar MSG65 Seat	●	
Integrated LED worklights	●	
Manual hydraulic levers	●	
<b>Common Options</b>	<b>Standard</b>	<b>Optional</b>
Alternative hydraulic controls (dual joysticks)		●
Fingertip control armrest		●
Battery extraction options		●
Additional lights and awareness options		●
PIN code access		●
Automatic tilt centering		●
Panel cabins		●
Side shifters		●
Fork positioners		●
Multiple tire options		●

Ask your local dealer about the available options for improved performance, productivity and operator comfort.

TACKLE YOUR TOUGHEST JOBS.

# EFFICIENTLY AND WITH EASE.



## Maneuverability and Control Systems

- **All-wheel steering** offers good grip, smooth turning and extremely agile steering aided by the +100 degree rear steer axle that enables side turns with minimal rear movement.
- **The Sensitive Drive System** is designed for rapid adaptation of performance in reaction to the commands of the operator, ensuring smooth starts, stops and hydraulic activity.
- **Front wheels** can be locked automatically at small steering angles or manually via an optional pedal function to increase traction on slippery surfaces
- **Hill hold** engages the brake system when the accelerator is released on a grade to hold the truck in place and not allow for unintended rolling down a ramp with a load.
- **Reactionary hydraulic system** proactively adjusts to the load weight for smooth and precise control of the mast and forks.
- **Load control** is increased with automatic hydraulic control tuning when lifting over certain heights and passive sway control allows for stress on the mast to be absorbed by the chassis.





## Performance

- 80V AC drive system delivers performance comparable to the internal combustion powered units but also includes the efficiency and total cost of ownership savings that come with our electric product line-up.
- The AC drive system automatically provides additional torque and acceleration when the operator needs it, even when carrying large loads.
- Standard wet disc brakes require less maintenance and allow for regenerative braking, sending energy back to the battery.
- Standard pre-set ECO and PRO modes allow the truck to be set at the level that is required by the application, but also the level necessitated by the experience of the operator.



## Ergonomics and Safety

- Integrated Presence System (IPS) includes lockout of both hydraulic and travel functions if the operator is not in the normal operating position in the seat.
- Quiet drive units keep the driver comfortable and can help increase awareness of surrounding areas.
- Spacious operator compartment is rubber-mounted to further minimize noise and vibration during operation.
- Easy and smooth entry/exit to/from the operator compartment.
- Emphasis on storage space for tools, mobile devices, bottles and other personal items make the truck a comfortable office space for operators.
- For low-light conditions, standard light-packages are included which provide forward and reverse LED lights for increased visibility.

CHARACTERISTICS			FB40N		FB45N		FB50CN		FB50N	
1	Capacity at rated load center	lb kg	9,000	4,082	10,000	4535	11,000	4,990	11,000	4,990
2	Load center -- distance	in mm	19.68	600	19.68	500	19.68	600	19.07	600
3	Power -- diesel, gasoline, LP gas, electric		Electric		Electric		Electric		Electric	
4	Tire type -- cushion, solid pneumatic		Solid pneumatic		Solid pneumatic		Solid pneumatic		Solid pneumatic	
5	Wheels (x=driven) number front / rear		2X/2		2X/2		2X/2		2X/2	
DIMENSIONS										
6	Maximum fork height (top of forks)	in mm	130.0	3,300	130.0	3,300	130.0	3,300	130.0	3,300
7	Free lift	in mm	5.9	150	5.9	150	5.9	150	5.9	150
8	Forks -- thickness x length x width	in mm	1.9 / 5.9 / 47.2	50/150/1,200	1.9 / 5.9 / 47.2	50/150/1,200	1.9 / 5.9 / 47.2	50/150/1,200	1.9 / 5.9 / 47.2	50/150/1,200
9	Fork spacing -- out-to-out minimum / maximum	in mm	11.8/44.3	300/1,125	11.8/44.3	300/1,125	11.8/44.3	300/1,125	11.8/44.3	300/1,125
10	Tilt -- forward / backward	deg°	6 / 8		6 / 8		6 / 8		6 / 8	
11	Overall length (with 42" long forks)	in mm	207.5	5,271	207.5	5,271	207.5	5,271	207.5	5,271
12	Length to fork face (includes fork thickness)	in mm	111.2	2,825	111.2	2,825	111.2	2,825	116.9	2,970
13	Overall width with standard tires	in mm	53.9	1,370	53.9	1,370	57.0	1,450	57.0	1,450
14	Overall width with wide stance tires	in mm	68.0	1,728	68.0	1,728	68.0	1,728	68.0	1,728
15	Height to top of lowered mast	in mm	95.3	2,420	95.3	2,420	95.3	2,420	95.3	2,420
16	Seat height to SIP	in mm	52.0	1,320	52.0	1,320	52.0	1,320	52.0	1,320
17	Height to top of overhead guard	in mm	92.1	2,340	92.1	2,340	92.1	2,340	92.1	2,340
18	Drawbar pin height	in mm	26.6	675	26.6	675	26.6	675	26.6	675
19	Height with mast raised	in mm	165.5	4,205	165.5	4,205	165.5	4,205	165.5	4,205
20	Minimum outside turning radius	in mm	90.1	2,289	90.1	2,289	90.1	2,289	95.8	2,434
21	Load distance, axle to fork face	in mm	21.3	540	21.3	540	21.3	540	21.3	540
22	Minimum aisle -- 90° stack - zero clearance without load	in mm	111.2	2,825	111.2	2,825	111.2	2,825	116.9	2,970
PERFORMANCE										
23	Travel speed -- loaded / empty	mph km/h	11 / 12	18 / 20	11 / 12	18 / 20	11 / 12	18 / 20	11 / 12	18 / 20
25	Lift speed -- loaded / empty	fpm mm/s	80.7 / 104.3	0.41 / 0.53	74.8 / 104.3	0.38 / 0.53	68.8 / 104.3	0.35 / 0.53	68.8 / 104.3	0.35 / 0.53
27	Lowering speed -- loaded / empty	fpm m/s	104.3 / 100.3	0.53 / 0.51	102.3 / 100.3	0.52 / 0.51	102.3 / 100.3	0.52 / 0.51	102.3 / 100.3	0.52 / 0.51
28	Gradeability -- loaded at 1 mph (1.6 km/h)	%	15%		15%		14%		14%	
30	Maximum gradeability -- loaded / empty	%	15.8 / 26.6		15.6 / 23.7		14.6 / 22.6		16.6 / 28.7	
WEIGHT										
31	Empty -- with minimum weight battery	lb kg	16,071	7,290	16,860	7,648	17,617	7,991	18,401	8,347
32	Axle load -- with rated load (front / rear)	lb kg	22,134 / 2,755	10,040 / 1,250	23,798 / 2,982	10,795 / 1,353	25,516 / 3,123	11,574 / 1,417	25,492 / 3,933	11,563 / 1,784
33	Axle load -- without rated load (front / rear)	lb kg	8,602 / 7,469	3,902 / 3,388	8,575 / 8,284	3,890 / 3,758	8,602 / 9,014	3,902 / 4,089	8,983 / 9,418	4,075 / 4,272
CHASSIS										
34	Tire size -- front, standard duals	in mm	250-15 / 7.00	711 x 225	250-15 / 7.00	711 x 225	355 / 50-15/9.75	710 x 284	355 / 50-15/9.75	710 x 284
35	Tire size -- rear	in mm	7.00-12 / 5.00	650 x 172	7.00-12 / 5.00	650 x 172	7.00-12 / 5.00	650 x 172	7.00-12 / 5.00	650 x 172
36	Wheelbase	in mm	76.6	1,946	76.6	1,946	76.6	1,946	82.3	2,090
37	Tread width -- front, standard tires	in mm	45.0	1,143	45.0	1,143	45.4	1,154	45.4	1,154
38	Tread width -- rear tires	in mm	46.0	1,169	46.0	1,169	46.0	1,169	46.0	1,169
39	Ground clearance -- at lowest point at mast	in mm	5.9	150	5.9	150	5.9	150	5.9	150
40	Ground clearance -- at center of wheelbase	in mm	5.9	150	5.9	150	5.9	150	5.9	150
41	Service brakes	type	Hydraulic		Hydraulic		Hydraulic		Hydraulic	
42	Parking brakes	type	Hydraulic		Hydraulic		Hydraulic		Hydraulic	
ELECTRICAL										
43	Battery type		lead-acid		lead-acid		lead-acid		lead-acid	
44	Battery capacity at 6 hr. discharge rate	Ah kWh	775	62	775	62	775	62	930	74.4
46	Battery weight, minimum	lb kg	3,880	1,760	3,880	1,760	3,880	1,760	3,880	1,760
47	Battery weight, maximum	lb kg	4,409.2	2,000	4,410	2,000	4,410	2,000	4,410	2,000
48	Battery compartment size, maximum	in mm	33.7 x 40.5 x 30.9	855 x 1,028 x 784	33.7 x 40.5 x 30.9	855 x 1,028 x 784	33.7 x 40.5 x 30.9	855 x 1,028 x 784	33.7 x 40.5 x 30.9	855 x 1,028 x 784
49	Drive motor capacity (60 min. rating)	HP kW	2,x,21.5	2 x 16	2 x 21.5	2 x 16	2 x 21.5	2 x 16	2 x 21.5	2 x 16
50	Lift output (15% rating)	HP kW	45.5	34	45.5	34	45.5	34	45.5	34
51	Drive / hydraulic controls	type	AC		AC		AC		AC	
52	Relief pressure for attachments	PSI Mpa	3,045	21.0	3,045	21.0	3,045	21.0	3,045	21.0
53	Flow rate for attachments	gpm lpm	12.0	45	12.0	45	12.0	45	12.0	45

**NOTE:** These specifications assume the use of drive axles, tires and tilt angles specified. Maximum converted value to gradeability at maximum torque of the traction motor. Any modification to specifications, or any other combination of specifications made after the shipment of the truck, requires prior written approval from Logisnext Americas Inc. (See ANSI/ITSDF B56.1.) Also be advised that overall operating visibility may be affected by the mast configuration and mast options of your truck. Therefore, you may need to add ancillary [auxiliary] devices or modify your operating practices. Consult your dealer for further information.

	FB50NH		FB55NH	
1	11,000	4,990	12,000	5,443
2	23.60	600	23.60	600
3	Electric		Electric	
4	Solid pneumatic		Solid pneumatic	
5	2X/2		2X/2	
6	130.0	3,300	130.0	3,300
7	6.3	160	6.3	160
8	2.3 / 5.9 / 47.2	60/150/1,200	2.3 / 5.9 / 47.2	60/150/1,200
9	11.8/44.3	300/1,125	11.8/44.3	300/1,125
10	6 / 8		6 / 8	
11	213.0	5,411	213.0	5,411
12	117.7	2,990	117.7	2,990
13	57.0	1,450	57.0	1,450
14	68.0	1,728	68.0	1,728
15	95.3	2,420	95.3	2,420
16	52.0	1,320	52.0	1,320
17	92.1	2,340	92.1	2,340
18	26.6	675	26.6	675
19	171.0	4,345	171.0	4,345
20	95.8	2,434	95.8	2,434
21	22.0	560	22.0	560
22	117.7	2,990	117.7	2,990
23	11 / 12	18 / 20	11 / 12	18 / 20
25	68.8 / 104.3	0.35 / 0.53	62.9 / 104.3	0.32 / 0.53
27	102.3 / 100.3	0.52 / 0.51	100.3 / 100.3	0.51 / 0.51
28	13.5%		13%	
	16.5 / 28.2		16.4 / 27.3	
31	18,677	8,472	19,204	8,711
32	26,475 / 3,225	12,009 / 1,463	28,216 / 3,112	12,799 / 1,412
33	9,334 / 9,343	4,234 / 4,238	9,360 / 9,843	4,246 / 4,465
34	355 / 50-15/9.75	710 x 284	355 / 50-15/9.75	710 x 284
35	7.00-12 / 5.00	650 x 172	7.00-12 / 5.00	650 x 172
36	82.3	2,090	82.3	2,090
37	45.4	1,154	45.4	1,154
38	46.0	1,169	46.0	1,169
39	5.9	150	5.9	150
40	5.9	150	5.9	150
41	Hydraulic		Hydraulic	
	Hydraulic		Hydraulic	
43	lead-acid		lead-acid	
44	930	74.4	930	74.4
46	4,435	2,010	4,431	2,010
47	5,180	2,350	5,048	2,350
48	39.3 x 40.5 x 30.9	999 x 1,028 x 784	39.3 x 40.5 x 30.9	999 x 1,028 x 784
49	2 x 21.5	2 x 16	2 x 21.5	2 x 16
50	45.5	34	45.5	34
51	AC		AC	
52	3,045	21.0	3,045	21.0
53	12.0	45	12.0	45

Call-out numbers shown in the diagram below correspond to the first column of the specifications chart.

# FB40N- FB55NH

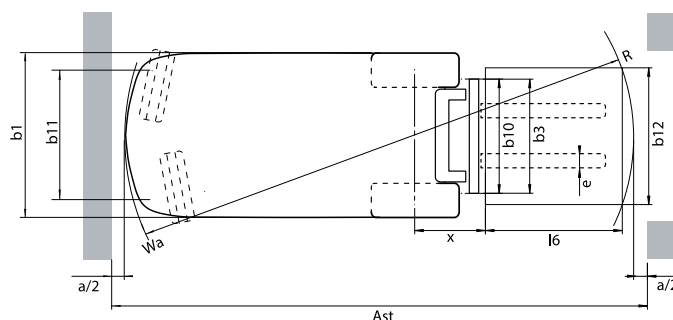
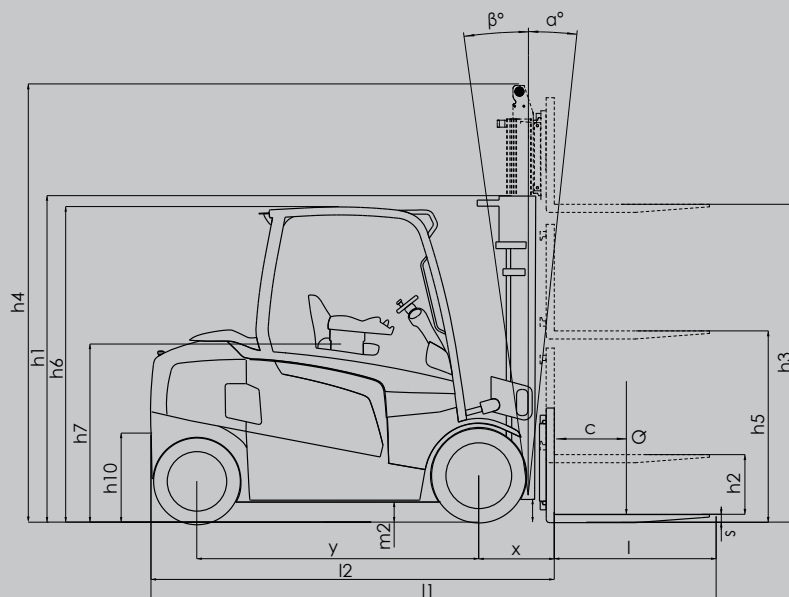

## SAFETY STANDARDS

These trucks meet American National Standards Institute/Industrial Truck Standards Development Foundation, ANSI/ITSDF B56.1. UL-Classified by Underwriters Laboratories, Inc., as to fire and electric shock hazard only; Type E, EE (optional), Industrial Trucks. Users should be aware of, and adhere to, applicable codes and regulations regarding operator training, use, operation and maintenance of powered industrial trucks, including:

- ANSI/ITSDF B56.1.
- NFPA 505, fire safety standard for powered industrial trucks -type designations, areas of use, maintenance and operation.
- Occupational Safety and Health Administration (OSHA) regulations that may apply.

Specifications, equipment, technical data, photos and illustrations based on information at time of printing and subject to change without notice. Some products may be shown with optional equipment.

Note: Equipping this model (these models) with a power source (e.g. Lithium-ion, Hydrogen Fuel cell, etc.) that has not been previously approved by the factory is considered a modification. Per OSHA 1910.178 and ANSI/ITSDF B56.1, please consult with your factory representative prior to installing any non-OEM power source that has not been previously approved.

# FB40N-FB55NH

8,000-12,000 LB CAPACITY ELECTRIC PNEUMATIC TIRE FORKLIFT

## Delivering Exceptional Value

### More Than 296,000 Parts To Keep You Running

Mitsubishi Forklift Trucks offers several parts programs, all designed to bring you top performance and convenience for your material handling needs. Contact your local dealer to put our services to work for you.

### Support To Fit Your Operation

Find out why more companies are relying on Mitsubishi forklift truck dealers to keep their fleet operating at top performance. Our efficiency provides customers with a better return on investment, and qualified service technicians, diverse parts inventory and unparalleled selection of service options can help reduce your total cost of ownership.

### Extensive Dealer Network

The Mitsubishi forklift truck dealer network is dedicated to finding the right forklift solution for your business. With more than 300 dealer locations, you can rely on your local dealer to provide the service you need when you need it most.



Manufactured with superior quality and exceptional value, Mitsubishi forklift trucks are supported by an extensive dealer and field support network located throughout North and South America. Don't forget to ask your local Mitsubishi forklift truck dealer about details on factory retail programs, financing plans and additional options and dealer services like planned maintenance and operator training.