

Runs 2 Shifts on 1 Battery Charge -  
Guaranteed on select models

Precise operation of travel and hydraulics  
with enhanced multifunction control handle  
options

Rigid mast allows for excellent load stability  
and capacity retention at higher heights

Spacious operator compartment, with sit-  
down operation capability, and extensive  
body padding for comfort, flexibility and  
functionality

Informative LCD premium display panel



## ETR 420 / 416d

### 36 Volt Electric Pantograph Reach Trucks (3,500 / 4,500 lbs.)

The ETR 420 single reach trucks and ETR 416d deep reach trucks boast superior performance – increasing hourly throughput and lowering overall cost of ownership – while keeping operators comfortable and productive.

- **High energy efficiency** – Run two shifts on one battery charge – The industry-exclusive Jungheinrich “2 Shifts, 1 Charge” program guarantees that the ETR series will run for two full shifts on one battery charge on select models – with no interim charging, no battery changing and no additional charging equipment needed.

#### The key advantages:

- **Exceptional performance** – These reach trucks’ hydraulic system can reach lifting speeds of up to 160 feet per minute, one of the fastest in the industry, allowing operators to move more product in less time.

- **Increased throughput** – the ETR series can run up to two shifts on one battery charge, helping your operators get the most out of their workday.
- **Premium ergonomics** – With a cabin that promotes operator relaxation and productivity, fatigue is greatly minimized. From being able to operate the truck in a sit-down position, to the low entry and exit step, to the intuitive, multifunctional control handles, there are several standard features that make this well-designed reach truck ideal for the operator. The steering column is similar to the ones used in our lineup of moving mast reach trucks, providing additional adjustment capabilities for enhanced comfort. Productivity can be just as high in the last hour of the shift as in the first.
- **Enhanced awareness** – All information is immediately accessible on the easy-to-read LCD operator display. Operators have three pre-programmed drive and hydraulic

performance modes to choose from, allowing them to customize the truck for a particular application or operator skill level.

- **Heavy-duty mast** – the Jungheinrich® ETR series features an enhanced-visibility, heavy-duty mast with durable rollers and mast rails designed to meet your most demanding applications. Combined with cushioning in mast staging functions, operators can precisely, securely and confidently position loads at all lift heights.
- **Maneuverability** – even with a slightly wider chassis than our traditional stand-up reach trucks, these reach trucks deliver greater productivity in applications where space is at a premium, such as narrow aisles and at high lift heights. Operators can also customize the drive and hydraulic settings to suit the application and their level of experience, ultimately making it easier to maneuver the machine.

**JUNGHEINRICH®**

# Technical Data

Characteristics	1		Model		ETR 420		ETR 416d			
	2		Type		Single Reach		Deep Reach			
	3		Power voltage		36		36			
Characteristics	4		Capacity at rated load center		lb	kg	4,500	2,000	3,500	1,600
	5		Capacity load center – distance from fork face		in	mm	24	600	24	600
Dimensions	6		Maximum fork height		in	mm	450	11,430	450	11,430
	7		Free fork height		in	mm	59	1,500	59	1,500
	8		Fork width		in	mm	3.9	100	3.9	100
	9		Fork thickness		in	mm	1.6	40	1.6	40
	10		Fork spacing - out-to-out minimum		in	mm	14.2	360	14.2	360
	11		Fork spacing - out-to-out maximum <sup>1)</sup>		in	mm	32.5	825	32.5	825
	12		Tilt angle - forward / backward		deg		3° / 4°		3° / 4°	
	12a		Reach stroke		in	mm	24	610	42	1,067
	13		Carriage width <sup>2)</sup>		in	mm	32.5	825	32.5	825
	14		Baseleg opening		in	mm	33-49	839-1,245	33-49	839-1,245
	15		Baseleg width <sup>3)</sup>		in	mm	5.5	140	5.5	140
	16		Overall length		in	mm	77.4	1,967	79.4	2,018
	17		Length to fork face		in	mm	56.0	1,422	63.3	1,607
	18		Overall chassis width		in	mm	48	1,220	48	1,220
	19		Overall lowered height		in	mm	107	2,720	107	2,720
	20		Overall height to top of overhead guard		in	mm	92.5	2,349	92.5	2,349
	21		Overall height with extended mast		in	mm	290	7,370	290	7,370
	22		Step height		in	mm	9.8	250	9.8	250
	23		Battery roller height		in	mm	7	178	7	178
	24		Minimum outside turning radius		in	mm	73.1	1,858	73.1	1,858
25		Minimum aisle - 90° stack - zero clearance		in	mm	Please consult your Jungheinrich dealer				
Performance	27		Grade clearance <sup>5)</sup>		%		14		14	
	28		Travel speed loaded/empty <sup>6)</sup>		mph	km/h	7.5 / 8.0	12.1 / 12.9	7.5 / 8.0	12.1 / 12.9
	30		Lift speed loaded / empty		fpm	m/s	90 / 165	0.45 / 0.86	90 / 165	0.45 / 0.86
	32		Lower speed loaded / empty		fpm	m/s	110 / 110	0.55 / 0.55	110 / 110	0.55 / 0.55
Weight	34		Gradeability - loaded / empty - maximum		%		9 / 10		9 / 10	
	35		Truck weight - empty - without battery		lb	kg	7,050	3,200	7,400	3,350
	36		Battery weight - min		lb	kg	2,000	910	2,000	910
37		Battery weight - max		lb	kg	2,300	1,050	2,300	1,050	
Wheels, Chassis	38		Chassis type (stand/sit)				Sit / Stand		Sit / Stand	
	39		Wheelbase		in	mm	62.9	1,597	62.9	1,597
	40		Ground clearance - center of wheelbase		in	mm	2.4	61	2.4	61
	41		Ground clearance - lowest point at mast		in	mm	2.4	61	2.4	61
	42		Tire size - steer		in	mm	13.5 5.5	343 x 140	13.5 x 5.5	343 x 140
	43		Tire size - caster		in	mm	7 x 4	180 x 100	7 x 4	180 x 100
	44		Tire size - load wheels		in	mm	5 x 3.62	127 x 92	5 x 3.62	127 x 92
45		Brake type				Electromagnetic Disc		Electromagnetic Disc		
Motors	46		Traction / pump / steer motor type				AC Induction		AC Induction	
	47		Traction motor output (60 minute rating)		hp	kW	9.2	6.9	9.2	6.9
	49		Pump motor output (5 minute rating)		hp	kW	27.2	20	27.2	20
	50		Steer motor output (60 minute rating)		hp	kW	1.0	0.7	1.0	0.7
Other	51		Battery maximum capacity - (6 hour rating)		A/H		1,120		1,120	
	52		Battery compartment length <sup>7)</sup>		in	mm	16.25	413	16.25	413
	53		Battery compartment width		in	mm	38.86	987	38.86	987
	54		Battery compartment height		in	mm	34.17	868	34.17	868

1) Maximum fork spacing 27.5 inches (698 mm) with 33 inch BLO.

2) Out-to-out dimension across mast outer channels.

3) 5.9 inches (150 mm) on single reach trucks with MFH over 332 inches (8430 mm).

4) 7.3 inches (186 mm) on single reach trucks with mast MFH above 332 inches (8430 mm).

5) Reduce grade clearance by 1.5% with 18.25 inch (463 mm) battery compartment length or 21.25 inch (539 mm) battery compartment length vs. 16.25 inch (412 mm) length.

6) Maximum speed attainable, after break-in period, varies with truck travel direction, weight, rolling resistance, mast height, options and battery condition.

7) 21.25 inch (539 mm) battery compartment length standard on chassis with MFH over 332 inches (8430 mm).

as of: 06/2021

# ETR 420 / 416d

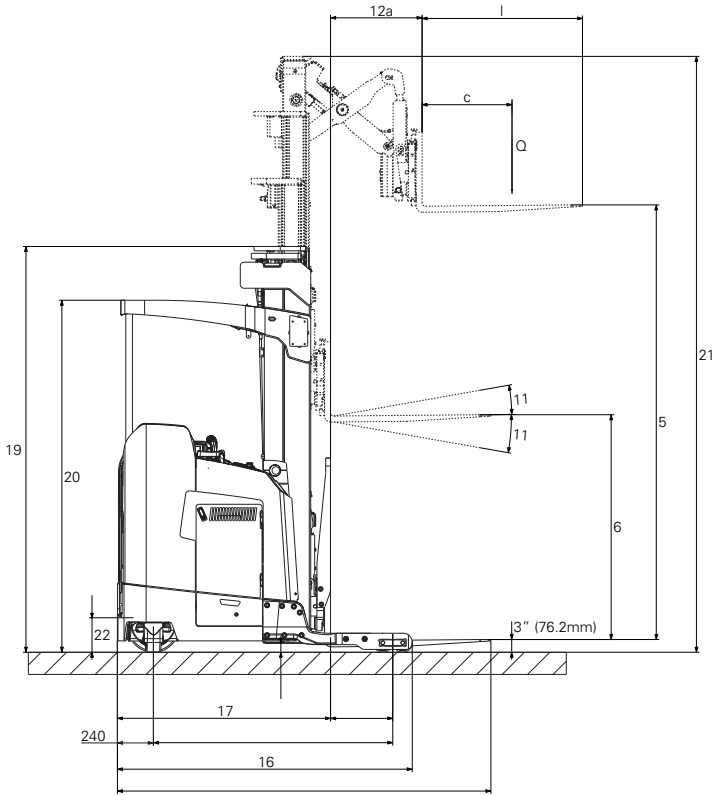
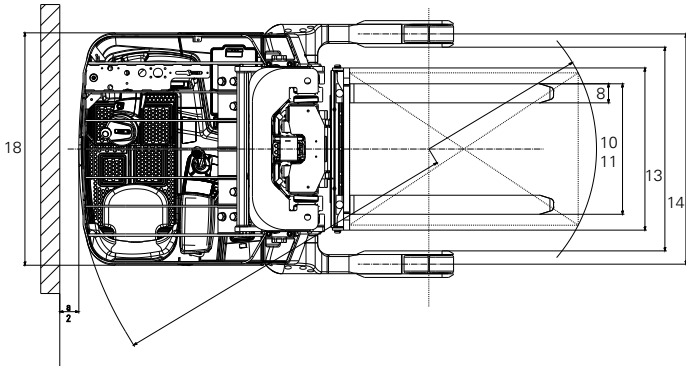

Add 9.1 in (230mm) for extended operator backrest

Note: Equipping this model (these models) with a power source (e.g. Lithium-ion, Hydrogen Fuel cell, etc.) that has not been previously approved by the factory is considered a modification. Per OSHA 1910.178 and ANSI/ITSDF B56.1, please consult with your factory representative prior to installing any non-OEM power source that has not been previously approved.

# The Jungheinrich Advantage



Overhead guard visibility

## Excellent visibility, heavy-duty mast

Jungheinrich masts provide excellent visibility and residual capacities to high lift heights.

- The strong mast and narrow, angled overhead guard promote excellent visibility to the load even in high stacking applications.
- The smooth mast staging and mast cushioning mechanism improve overall material handling performance by reducing the risk of damaging loads, racks and surroundings.
- Shim-adjustable canted mast rollers.
- Heavy, interlocking mast rails.
- Optional integral sidsifter helps improve maneuverability.
- Fork heights up to 450 inches.

## Powerful Jungheinrich AC technology

3-phase AC technology for drive, lift and steering offers several advantages over traditional direct current motors.

- Rapid acceleration and precise speed control.
- Smooth directional changes.
- Greater uptime due to maintenance-free motors without carbon brushes and less wear components.
- Longer operating times due to energy reclamation during braking.

## Customized programming

Performance profiling allows you to customize the reach truck's drive and hydraulic settings based on your application, individual operator experience level and personal preferences. All display-based programming, performance and information requests can be performed with easily-accessible buttons.



Multifunction control handle

## Multifunction control handle

The intuitive, multifunction control handle is centrally positioned for easy access to truck functions.

- Maximum efficiency through simultaneous operation of travel, lift and auxiliary hydraulic functions.
- Rounded palm rest helps reduce operator fatigue over long shifts.
- Optional horizontal multifunction ECHO control handle available for added flexibility and operating preference.

## Lithium-Ion Availability:

- Greater power efficiency
- Run for 24 hours a day, 7 days a week with opportunity charging
- Zero battery maintenance
- No watering
- No more battery exchanges
- No gas emissions, odor or acidification
- No special charging areas or equipment needed
- Longer lasting life cycles (up to 3,000)
- 5-year warranty on batteries
- 2-year warranty on chargers

## Operator control panel

The easy-to-read display panel provides the operator with key information to complete his day-to-day tasks.

- Battery discharge indicator
- 180° / 360° steer direction indicator
- Parking brake indicator
- Clock
- Hour meter
- Performance mode selector (1-3)



Operator compartment

## Spacious and ergonomic operator compartment

The spacious, slightly wider than the traditional operator compartment, combines comfort and functionality to improve operator efficiency.

- Location of operator controls allows for a flexible side stance position or sit-down operation within the compartment.
- Dual operator pedals allow for standing or sit-down operation.
- Low-effort electric power steering for precise control with minimal effort.
- Highly-informative display provides the operator with vital information at just a quick glance.
- Anti-fatigue floor mat and generous padding for knees, hips, back and armrest.
- Storage space for operator's equipment, paperwork and materials.

## Parts when you need them

Jungheinrich's Parts Fast or Parts Free Guarantee ensures next-business-day delivery by 5:00 PM of all Jungheinrich parts in the United States, or they're free, including freight. For customers in Canada and Mexico, the guarantee ensures shipping of parts within 24 hours from the time the order was placed by the dealer. See your local Jungheinrich dealer for program details.

\* Programs may be subject to change without notice and may vary by region. Please ask your local Jungheinrich dealer for complete terms and conditions.